

(12) **United States Patent**
Brienza et al.

(10) **Patent No.:** **US 10,376,412 B2**
(45) **Date of Patent:** **Aug. 13, 2019**

(54) **ACTIVELY AND SELECTIVELY COOLED CUSHIONING SURFACE**

(71) Applicants: **David M. Brienza**, Allison Park, PA (US); **Patricia E. Karg**, South Park, PA (US); **Andrew J. Malkiewicz**, Pittsburgh, PA (US)

(72) Inventors: **David M. Brienza**, Allison Park, PA (US); **Patricia E. Karg**, South Park, PA (US); **Andrew J. Malkiewicz**, Pittsburgh, PA (US)

(73) Assignee: **University of Pittsburgh—Of The Commonwealth System of Higher Education**, Pittsburgh, PA (US)

(*) Notice: Subject to any disclaimer, the term of this patent is extended or adjusted under 35 U.S.C. 154(b) by 1404 days.

(21) Appl. No.: **13/943,772**

(22) Filed: **Jul. 16, 2013**

(65) **Prior Publication Data**
US 2014/0228918 A1 Aug. 14, 2014

Related U.S. Application Data

(60) Provisional application No. 61/672,202, filed on Jul. 16, 2012.

(51) **Int. Cl.**
A61F 7/00 (2006.01)
A61F 7/02 (2006.01)
A61F 7/10 (2006.01)

(52) **U.S. Cl.**
CPC **A61F 7/10** (2013.01); **A61F 2007/0056** (2013.01); **A61F 2007/0076** (2013.01); **A61F 2007/0219** (2013.01); **A61F 2007/0268** (2013.01)

(58) **Field of Classification Search**

CPC A61F 2007/029; A61F 2007/0054–0056; A61F 2007/0075; A61F 2007/0076; A61F 2007/0219; A61F 2007/0268; A61F 2007/0273
See application file for complete search history.

(56) **References Cited**

U.S. PATENT DOCUMENTS

2,648,325 A * 8/1953 Siple A41D 13/0051 126/204
3,136,577 A * 6/1964 Richard B60N 2/5692 219/202
4,846,176 A * 7/1989 Golden A61F 7/02 165/46
4,854,319 A * 8/1989 Tobin A61F 7/10 2/171.2
4,962,761 A * 10/1990 Golden A61F 7/02 165/46

(Continued)

Primary Examiner — Kaitlyn E Smith

(74) *Attorney, Agent, or Firm* — Paul D. Bangor, Jr.; Clark Hill PLC

(57) **ABSTRACT**

A cushioning surface for cooling tissue that reaches a predefined level of immersion into the cushioning surface, comprising: a segmented fluid cushion comprising a plurality of cells interconnected to allow fluid to flow from each cell to at least one of the other plurality of cells; and wherein one or more of the plurality of cells contains a heat exchange material. The cushioning surface may further comprise a cooling element associated with and for removing heat from the one or more cells containing a heat exchange material.

12 Claims, 8 Drawing Sheets

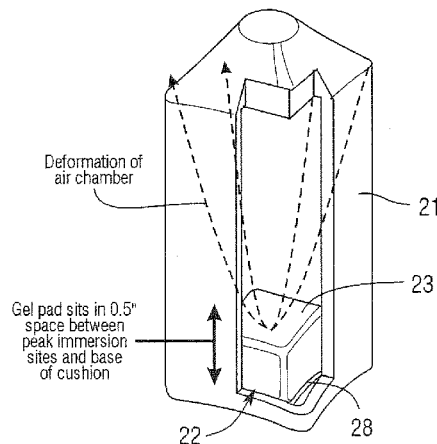

Thermoelectrically cooled air cell under load

(56)

References Cited

U.S. PATENT DOCUMENTS

5,010,608	A *	4/1991	Barnett	A61G 7/05776	5/713	2008/0077202	A1 *	3/2008	Levinson	A61F 7/02	607/96
5,456,703	A *	10/1995	Beeuwkes, III	A61F 7/02	607/109	2008/0287839	A1 *	11/2008	Rosen	A61F 7/10	601/18
5,533,217	A *	7/1996	Holdredge	A61G 5/1043	5/710	2009/0033130	A1 *	2/2009	Marquette	A47C 7/74	297/180.15
5,840,080	A *	11/1998	Der Ovanesian	A61F 7/02	607/112	2009/0198311	A1 *	8/2009	Johnson	A61F 7/106	607/109
5,957,964	A *	9/1999	Ceravolo	A61F 7/10	607/109	2009/0287281	A1 *	11/2009	Munson	A61F 7/02	607/104
5,989,285	A *	11/1999	DeVilbiss et al.	...	A47C 21/044	607/104	2010/0274332	A1 *	10/2010	Hirakawa	A47C 21/042	607/114
6,235,049	B1 *	5/2001	Nazerian	A61F 7/007	607/108	2011/0307040	A1 *	12/2011	Peterson	A61F 7/02	607/108
6,800,088	B1 *	10/2004	Karapetyan	A61F 7/103	607/104	2012/0065715	A1 *	3/2012	Carson	A61F 7/10	607/104
6,927,316	B1 *	8/2005	Faries, Jr.	A41D 13/1245	602/14	2012/0305231	A1 *	12/2012	Liang	A61F 7/0241	165/287
7,744,640	B1 *	6/2010	Faries, Jr.	A61F 13/00	607/108	2013/0067662	A1 *	3/2013	Jusiak	B32B 3/26	5/724
9,433,525	B2 *	9/2016	Parish	A61F 7/0097	607/104	2013/0079684	A1 *	3/2013	Rosen	A61F 7/10	601/11
2005/0256556	A1 *	11/2005	Schirmacher	A61F 7/02	607/104	2013/0116760	A1 *	5/2013	Carson	A61F 7/10	607/104
2006/0060344	A1 *	3/2006	Esaki	B60H 1/00285	165/287	2013/0269106	A1 *	10/2013	Brykalski	A47C 21/048	5/423
2007/0135878	A1 *	6/2007	Lachenbruch	A61G 7/057	607/108	2014/0214138	A1 *	7/2014	Voorhees	A61F 7/10	607/104
2007/0150033	A1 *	6/2007	Johnson	A61F 7/106	607/114	2015/0107601	A1 *	4/2015	Arnone	A61F 7/03	128/845
							2016/0128487	A1 *	5/2016	Eskridge, III	A47C 21/048	5/423

* cited by examiner

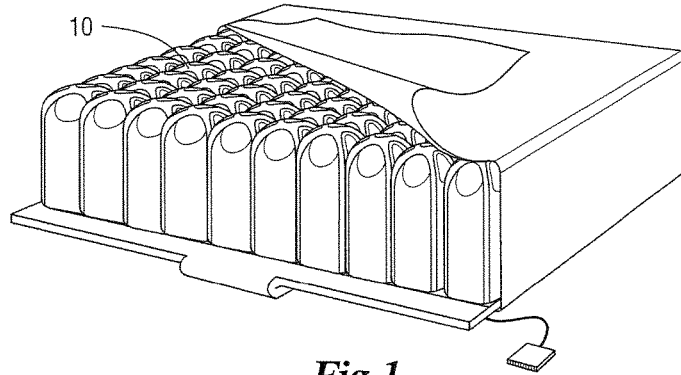
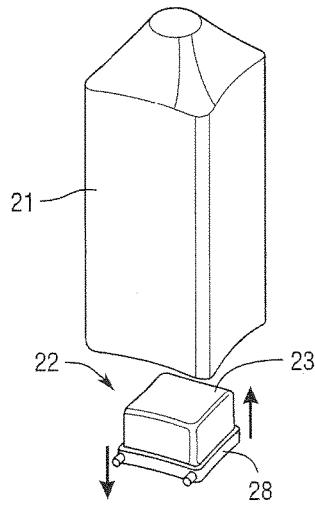
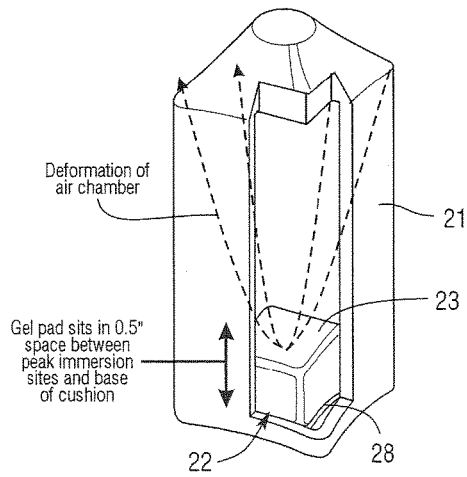

Fig.1



Individual cooling elements situated inside air chambers
A gel pad sits atop a thermoelectric cooler and the chamber is resealed using neoprene epoxy

Fig.2



Thermoelectrically cooled air cell under load

Fig.3

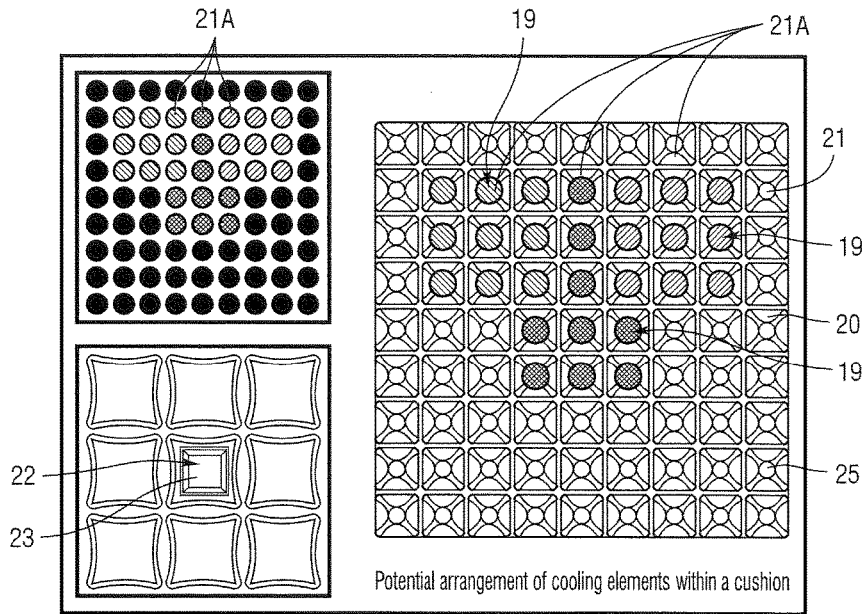
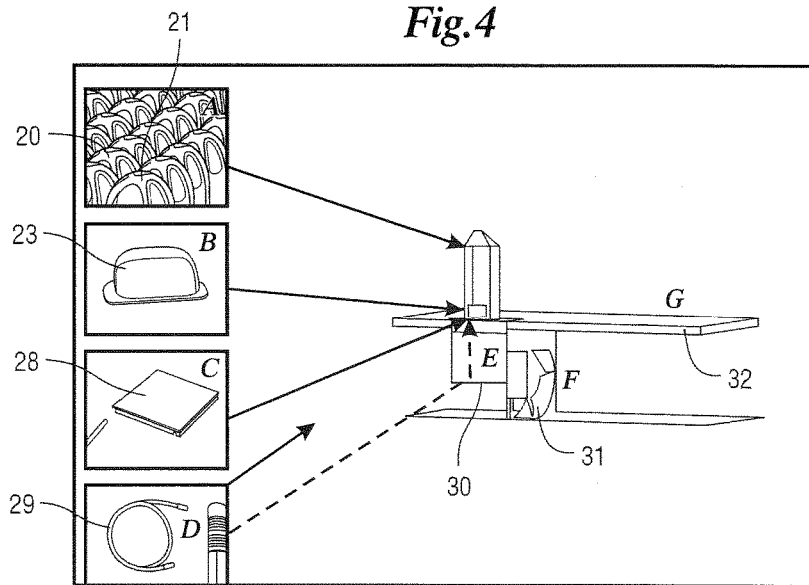

Fig. 4



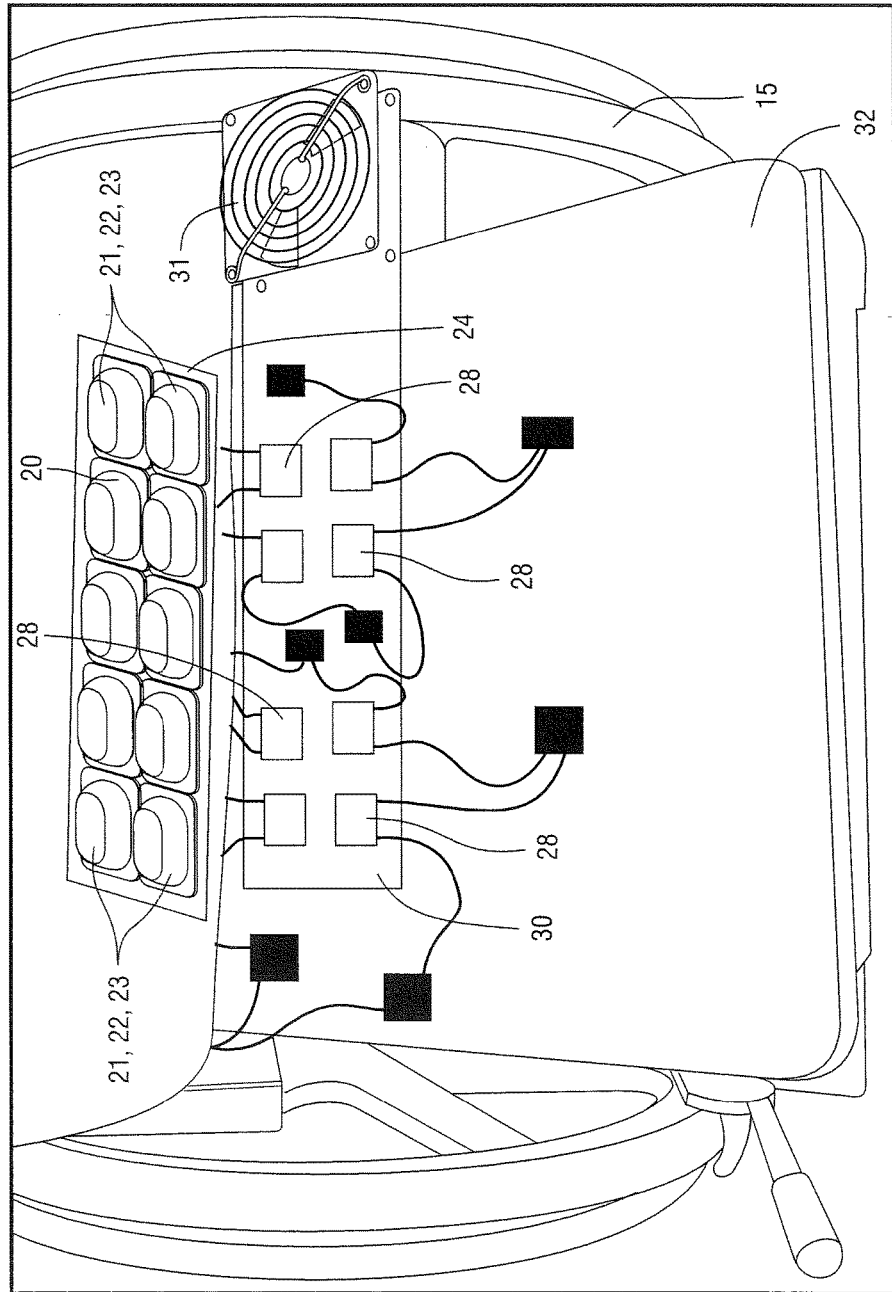

Fig.5A

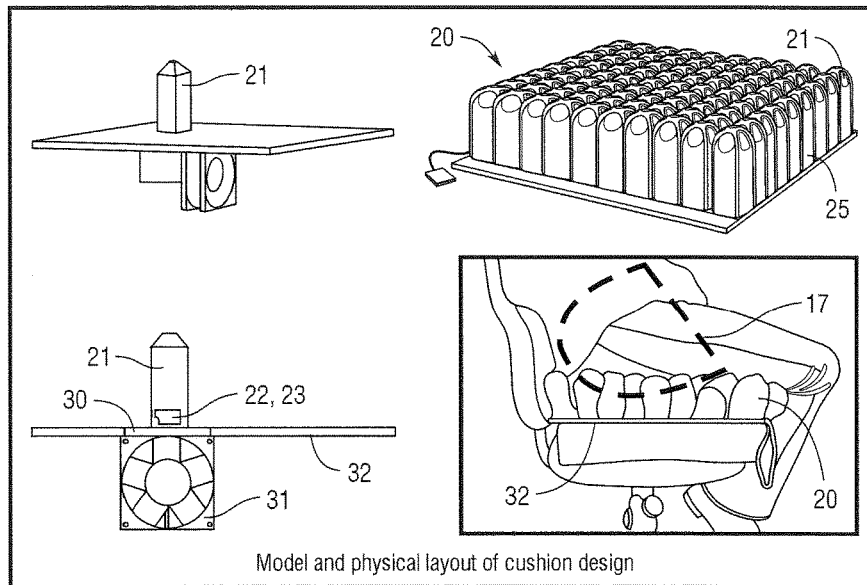

Fig.6

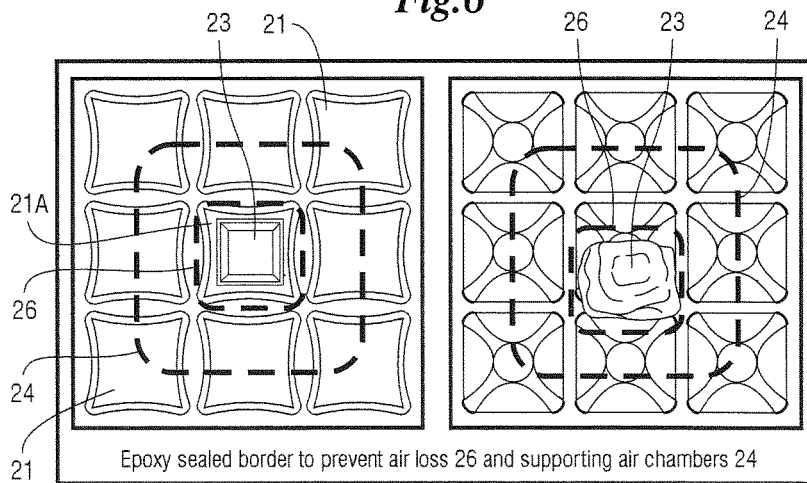

Fig.7

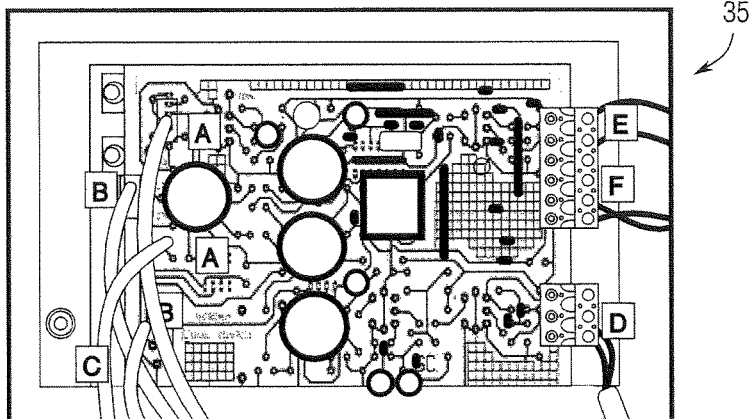
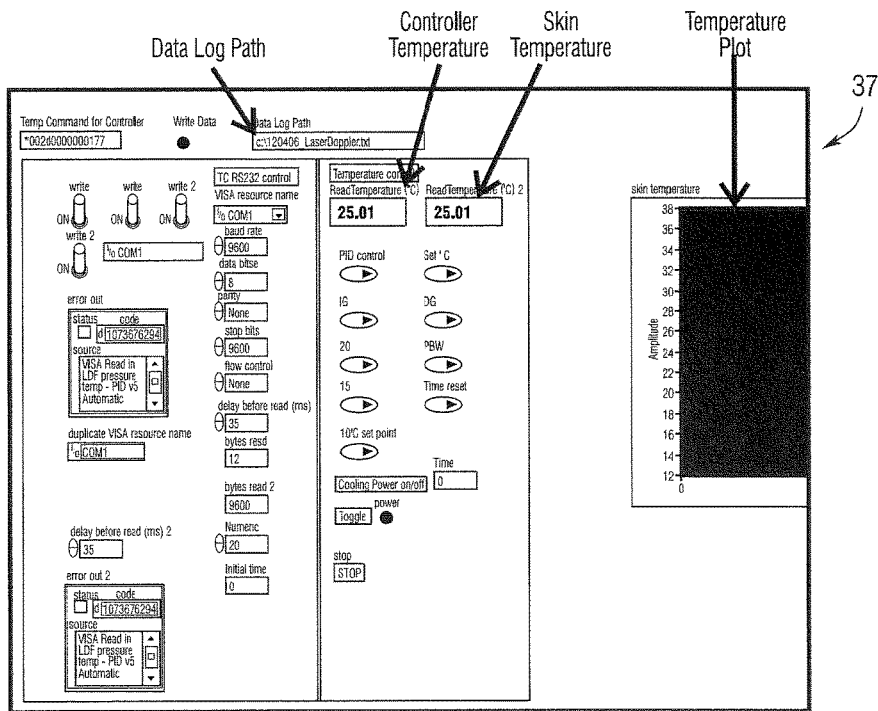

Fig. 8



Labview control program GUI

Fig. 9

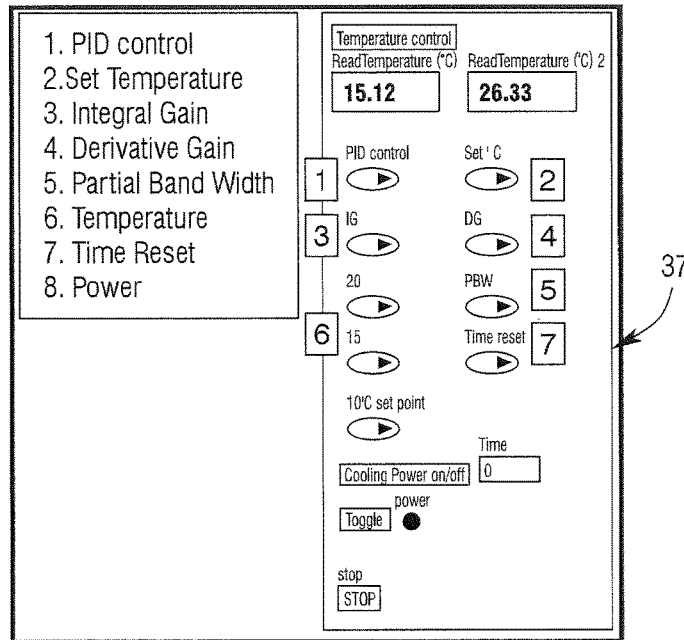
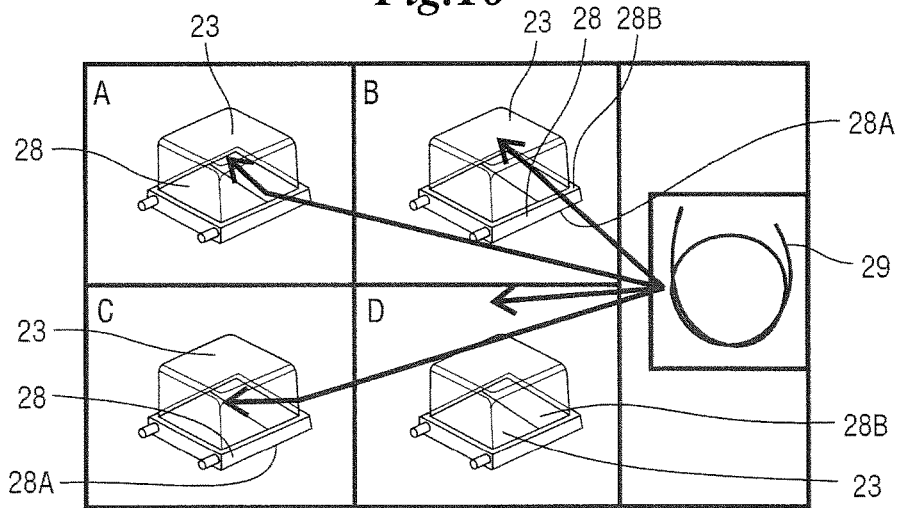

Fig.10



Control thermistor test locations. (A) Within Gel. (B) Above Gel. (C) Below gel in contact with TEC. (D) On skin of seated user

Fig.11

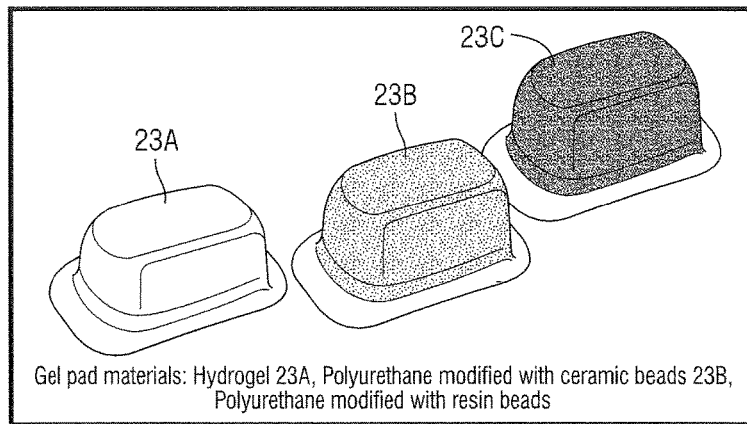

Fig. 12

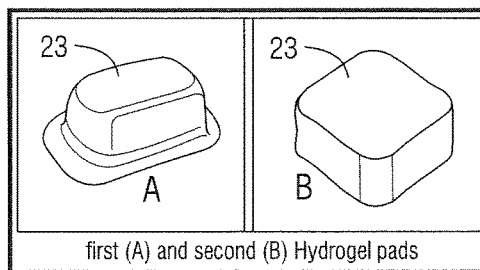

Fig. 13

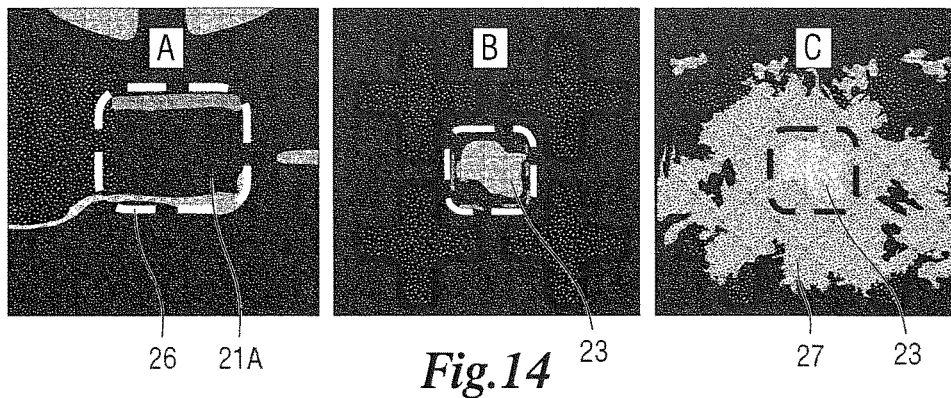
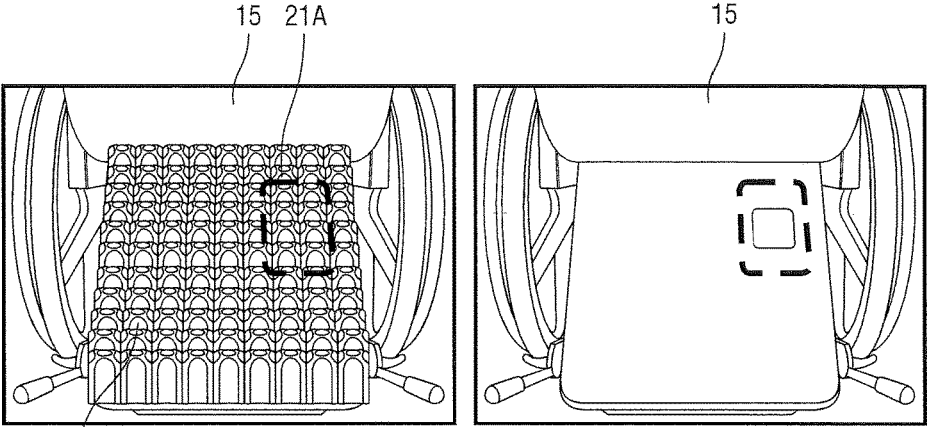

Fig. 14



20 Fig.15A

Fig.15B

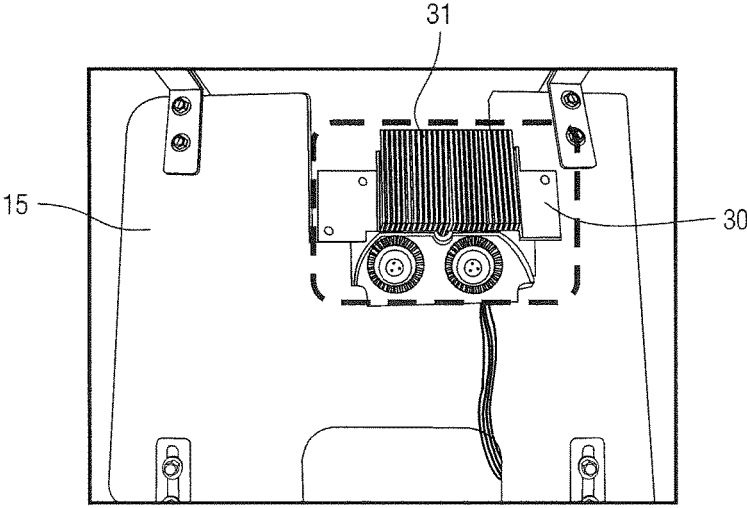

Fig.16

1

**ACTIVELY AND SELECTIVELY COOLED
CUSHIONING SURFACE**

RELATED APPLICATIONS

This application claims priority benefit under 35 U.S.C. § 119(e) of U.S. Provisional Patent Application No. 61/672, 202, filed Jul. 16, 2012, the contents of which are herein incorporated by reference.

GOVERNMENTAL RIGHTS

This invention was made with government support under Grant #H133E070024 awarded by the United States Dept of Education, National Institute on Disability and Rehabilitation Research (Federal-non-NIH). The government has certain rights in the invention.

TECHNICAL FIELD

The present disclosure generally relates to cushioning surfaces for use in wheelchair seating/support applications and other applications including, without limitation, beds, mattresses, mattress overlays, operating table pads, face masks, helmets and shoe insoles and, more specifically, to cushioning surfaces having areas that may be actively and selectively cooled depending upon the application and particularly where a cushioned body part or tissue reaches a predefined level of immersion into the cushioning surface.

BACKGROUND

Pressure ulcers result from excessive pressure applied to fragile tissue over an extended period of time. The wounds usually occur over bony prominences where weight bearing soft tissue is compressed. The most common anatomical locations are the sacrum, heels and ischial tuberosities. Known risk factors include pressure, shear force, heat, moisture, aging skin, immobility, lack of sensation, poor nutrition, diabetes and a host of other conditions. The cause is believed to be ischemia, ischemia-reperfusion injury, or simply mechanical damage due to cell deformation. Populations at high risk include the immobile elderly, persons with paralysis and/or neurological deficits, and people undergoing long surgical procedures. Primary prevention involves frequent repositioning and the provision of a cushioning surface that redistributes pressure away from vulnerable areas.

Fifteen years ago, a group of researchers at the University of Minnesota (Kokate et al., 1995) demonstrated the critical importance of skin temperature to the susceptibility of tissue to ulceration when the tissue is exposed to ischemia inducing compressive forces. In an experiment on the backs of swine, pressure (100 mmHg) was selectively applied with skin temperature controlled at 25° C., 35° C., 40° C. and 45° C. for five hour periods. Histological examination at 7 days post-procedure showed that all tissue layers were normal under 25° C., while moderate muscle damage was found at sites with 35° C., and tissue necrosis at all layers was found at sites with 45° C. In a follow up study, Iazzo (1995) narrowed the temperature range to 25° C., 27° C., 30° C. and 32° C. in an attempt to find a critical temperature. The results were not conclusive, but based on the relationship between temperature and damage severity that they observed, they suggested temperatures below 30° C. had a protective effect for the conditions of the experiment. The fundamental effect of the cooling is believed to be a lowering of the metabolic

2

rate (consumption of O₂) in ischemic tissue allowing the cells to survive for a longer period of time without oxygen.

Despite Kokate and Iazzo's demonstration of the prophylactic effect of maintaining skin temperature at levels below core body temperature and below typical skin temperature, no cushions, mattresses, operating table overlays, or other cushioning surfaces have been brought to market that actively cool the skin in an attempt to prevent pressure ulcers. Possible explanations for this are numerous, but chief among them is the undesirable effect of lowering core body temperature in an attempt to cool the skin impacted by weight bearing. A potential solution is to limit the location where cooling is applied to only those locations where pressure exceeds a given threshold, thus limiting the overall effect on the body while cooling the most critical areas. Iazzo and others, e.g., Augustine, et al., U.S. Pat. No. 6,497,720, teach the concept of applying active cooling in response to pressure. Such pressure sensitive cooling techniques for cushioning are complex. A simpler approach according to preferred embodiments of the present disclosure comprises an actively and selectively cooled cushioning surface with embedded cooling mechanisms that cool tissue that reaches a predefined level of immersion into the cushioning surface (i.e., immersion-based cooling).

SUMMARY

One aspect of a preferred embodiment of the present disclosure comprises a cushioning surface for cooling tissue that reaches a predefined level of immersion into the cushioning surface, comprising: a segmented fluid cushion comprising a plurality of cells interconnected to allow fluid to flow from each cell to at least one of the other plurality of cells; and wherein one or more of the plurality of cells contains a heat exchange material. The cushioning surface may preferably further comprise a cooling element associated with and for removing heat from the one or more cells containing a heat exchange material.

In another aspect of a preferred embodiment of the present disclosure, the cushioning surface preferably comprises top and bottom surfaces and the heat exchange material is disposed between the top surface and the cooling element.

In an additional aspect of a preferred embodiment of the present disclosure, the cushioning surface preferably further comprises a separate cooling element associated with each of the one or more cells containing heat exchange material for removing heat from the heat exchange material in each such cell.

In another aspect of a preferred embodiment of the present disclosure, the cushioning surface preferably comprises top and bottom surfaces and the heat exchange material is disposed between the top surface and the separate cooling element in each of the one or more cells containing heat exchange material.

In yet another aspect of a preferred embodiment of the present disclosure, the cushioning surface may preferably comprise a plurality of air-filled cells.

In another aspect of a preferred embodiment of the present disclosure, the cushioning surface may preferably comprise a cooling element comprising a powered thermoelectric cooler.

In a further aspect of a preferred embodiment of the present disclosure, the cushioning surface may preferably comprise a heat exchange material comprising a compliant material or gel.

3

In another aspect of a preferred embodiment of the present disclosure, the cushioning surface may preferably comprise a plurality of cells each containing heat exchange material and having a separate cooling element associated therewith.

In an additional aspect of a preferred embodiment of the present disclosure, the cushioning surface may preferably one or more cells each containing heat exchange material and having a separate cooling element associated therewith and corresponding to an area where immersion of tissue into the cushioning surface at the predefined level is expected to occur from a body supported by the cushioning surface or from a person seated on the cushioning surface.

Another aspect of a preferred embodiment of the present disclosure comprises a cushioning surface for cooling tissue that reaches a predefined level of immersion into the cushioning surface, comprising: a segmented fluid cushion comprising a plurality of cells interconnected to allow fluid to flow from each cell to at least one other of the plurality of cells; wherein a plurality of the plurality of cells contains a heat exchange material; a separate cooling element associated with each of the cells containing heat exchange material for removing heat therefrom; and wherein the cushioning surface comprises top and bottom surfaces and the heat exchange material is disposed between the top surface and the separate cooling element in each of the cells containing heat exchange material.

In an additional aspect of the cushioning surface a preferred embodiment of the present disclosure, each cell containing heat exchange material and having a separate cooling element associated therewith corresponds to an area where immersion of tissue into the cushioning surface at the predefined level is expected to occur from a body supported by the cushioning surface or from a person seated on the cushioning surface.

Another aspect of a preferred embodiment of the present disclosure comprises a cushioning surface for cooling tissue that reaches a deep level of immersion into the cushioning surface, comprising: a segmented air cushion comprising a plurality of cells interconnected to allow air to flow from each cell to at least one other of the plurality of cells; wherein at least one of the plurality of cells contains a heat exchange material; a separate cooling element associated with the at least one cell containing heat exchange material for removing heat therefrom; wherein the cushioning surface comprises top and bottom surfaces and the heat exchange material is disposed between the top surface and the separate cooling element in each of the at least one cell containing heat exchange material; and wherein the at least one cell containing heat exchange material and having a separate cooling element associated therewith corresponds to an area where deep immersion of tissue into the cushioning surface is expected to occur. Here, each separate cooling element may preferably comprise a powered thermoelectric cooler.

BRIEF DESCRIPTION OF THE DRAWINGS

The present disclosure is illustrated by way of example and not limitation in the figures of the accompanying drawings, in which:

FIG. 1 shows an example of a typical, known segmented air, pressure reducing cushion.

FIG. 2 shows an exploded view of an individually cooled cell of an actively and selectively cooled cushioning surface according to a preferred embodiment of the present disclosure.

4

FIG. 3 shows a cut-away view of an individually cooled cell of an actively and selectively cooled cushioning surface according to a preferred embodiment of the present disclosure.

FIG. 4 shows several preferred patterns of individually cooled cells in an actively and selectively cooled cushioning surface according to preferred embodiments of the present disclosure.

FIG. 5 shows a cut-away view of an individually cooled cell with an associated heat sink and fan of an actively and selectively cooled cushioning surface according to a preferred embodiment of the present disclosure.

FIG. 5A shows a preferred embodiment of a wheelchair having a seat comprising an actively and selectively cooled cushioning surface according to a preferred embodiment of the present disclosure.

FIG. 6 shows various views and placements of an actively and selectively cooled cushioning surface and components thereof according to a preferred embodiment of the present disclosure.

FIG. 7 shows placement and construction of an individually cooled cell of an actively and selectively cooled cushioning surface according to a preferred embodiment of the present disclosure.

FIG. 8 shows a controller for use with an actively and selectively cooled cushioning surface according to a preferred embodiment of the present disclosure.

FIG. 9 shows a GUI of a software program for use with an actively and selectively cooled cushioning surface according to a preferred embodiment of the present disclosure.

FIG. 10 shows another GUI of a software program for use with an actively and selectively cooled cushioning surface according to a preferred embodiment of the present disclosure.

FIG. 11 shows preferred placements for control thermistors used with an actively and selectively cooled cushioning surface according to preferred embodiments of the present disclosure.

FIG. 12 shows preferred heat exchange materials in pad form for use in an actively and selectively cooled cushioning surfaces according to preferred embodiments of the present disclosure.

FIG. 13 shows preferred heat exchange materials in pad form for use in an actively and selectively cooled cushioning surfaces according to preferred embodiments of the present disclosure.

FIG. 14 shows placement and construction of an individually cooled cell of an actively and selectively cooled cushioning surface according to a preferred embodiment of the present disclosure.

FIG. 15A shows a preferred embodiment of a wheelchair having a seat comprising an actively and selectively cooled cushioning surface according to a preferred embodiment of the present disclosure.

FIG. 15B shows another view without seat cushion of the wheelchair of FIG. 15A as modified for use with an actively and selectively cooled cushioning surface according to a preferred embodiment of the present disclosure.

FIG. 16 shows a bottom view of a seat of a wheelchair modified for use with an actively and selectively cooled cushioning surface according to a preferred embodiment of the present disclosure.

DETAILED DESCRIPTION OF PREFERRED EMBODIMENTS

The following description, taken in conjunction with the referenced drawings, is presented to enable one of ordinary

skill in the art to make and use the disclosure and to incorporate it in the context of particular applications. Various modifications, as well as a variety of uses in different applications, will be readily apparent to those skilled in the art, and the general principles, defined herein, may be applied to a wide range of aspects. The present disclosure is not intended to be limited to the aspects disclosed herein. Instead, it is to be afforded the widest scope consistent with the disclosed aspects.

According to a preferred embodiment of the present disclosure, cushioning surface **20** is actively and selectively cooled while also providing adequate cushioning effect for pressure redistribution. Immersion is defined as the depth of penetration into a support surface (National Pressure Ulcer Advisory Panel 2006); distributing excess pressure to surrounding areas through immersion remains the fundamental strategy to reduce pressure near bony prominences (Brienza, et al. 2008). Lower density materials such as foam and constructs such as air chambers do not have the capacity to transfer heat away from the skin effectively. Denser materials with better heat transfer characteristics generally do not allow adequate immersion and envelopment for effective pressure redistribution.

Prior studies have shown that pressure reducing cushions (PRCs) protect tissue integrity better than standard foam cushions (Geyer, et al. 2001). Pressure reducing cushions preferably can be constructed from a variety of materials including: viscoelastic foams, gels, water or other fluids, and segmented air cells (Sprigle, Press and Davis 2001). Multi-cell air cushions have been shown to provide superior pressure redistribution and are among the most effective types of wheelchair cushions. Typical, segmented air cell cushions **10** known in the art, such as the ROHO Cushion shown in FIG. 1, use a system of air cells that are made of neoprene rubber. Narrow channels that allow air to flow at a controlled rate from cell to cell interconnect the soft, flexible cells. A properly inflated segmented air cushion generally will allow a seated person to sink to within roughly 0.5 inches of clearance between the buttocks and the bottom of the cushion.

Preferred cushioning surfaces **20** of the present disclosure for cooling tissue that reaches a predefined level of immersion into cushioning surface **20** selectively cool deep immersed tissue without adversely affecting the pressure redistribution characteristics of the cushioning surface. According to preferred embodiments of the present disclosure, a preferred active and selectively cooled cushioning surface **20** contains one or more cooling elements **22**, comprising a soft or compliant material with good heat exchange/conduction properties that are located deep within one or more individual cells or chambers **21** (see FIG. 4 for patterns **19** of individual cells **21A** containing cooling elements **22** within cushioning surface **20** so that the cooling elements **22** only come in contact with tissue or body parts protruding deep into the cushioning surface **20**). By introducing cooling elements **22** into the clearance space between the deeply immersed parts of the body and the bottom of the cushioning surface **20**, zones of deepest immersion that correspond to areas of greatest risk of developing pressure ulcers are targeted for cooling.

Preferably, electrically powered thermoelectric coolers (TECs) **28** form a part of cooling elements **22** and are used to draw heat from pads **23** of compliant heat exchange material disposed in the targeted areas under the bony prominences of a supported or seated individual. The TECs **28** work by transferring heat from one side of the device to the other side against a temperature gradient (from cold to

hot). Using several TECs **28** within or associated with the cushioning surface **20** will allow select areas of highest immersion beneath a seated or otherwise supported individual to be selectively cooled without inducing a systemic hypothermic response throughout the person's body.

As shown in drawings, particularly, FIGS. 2-7, preferably, gel pads or blocks **23** of compliant heat exchange material serve as the component of cooling elements **22** disposed between the TECs **28** and the seated or supported individual.

There are two primary benefits to this approach; first that a soft, contouring gel pad **23** would have better contact with the skin and allow the cooling to be delivered more effectively. Second, the cushioning effect of the gel pad **23** can protect the user from the force applied when the user sits upon or is otherwise supported by cushioning surface **20** at the location of the TECs **28**, where at the areas of deep immersion, the tissue or body part is likely to encounter components of the cooling elements **22** rather than the cushion of air in the clearance space of individual cells **21**.

As shown in FIGS. 4-16, the hot side **28A** of the TEC **28** (cool side of the TEC **28** is **28B**) will be attached to or associated with a heat sink **30** to draw the generated heat away from the TEC **28** and gel pad **23**. As the air cells **21** deform, the buttocks would come in contact with the gel pad **23**, which is cooled by the TEC **28** situated at the base of cell **21A** of cushioning surface **20**.

Preferably, cooling elements **22** are arranged in arrays throughout cushioning surface **20** depending on the needs of the user. As shown in FIG. 4, different zones **19** beneath a user can be individually controlled and calibrated to cover small or large areas of targeted cooling through placement of cells **21A** having cooling elements **22** disposed therein or associated therewith. Alternately, the cooling elements **22** might be activated when contact between the roof of the air chamber **21** and the gel block **23** is detected. Preferably, cooling properties (targeted temperature, cooling rate, etc.) will be determined based upon examining the effects of cooling.

Materials suitable for use as the gel pad **23** interface between the TECs **28** and a user seated or supported on the top **25** of cushioning surface **20** preferably need to be soft enough to produce relatively low reaction to increases in pressure when a user is in contact therewith, and thermally conductive enough to be cooled by the TEC **28** below while accepting the heat at the body surface interface. Conventional gel materials coupled with thermally conductive additives preferably allow gel pads **23** to combine requisite properties into one gel pad **23**. Additional modifications could preferably be made to the housing material of each air cell **21**, either through additives or modifications of thicknesses, which could further enhance the cooling effectiveness of TECs **28**. In addition, other compliant materials such as phase change materials, like those disclosed in U.S. Pat. No. 6,699,266 (incorporated herein by reference), maybe used as the heat absorbing compliant element **23** embedded in individual cells **21A** of cushioning surface **20**.

Cushioning surface **20** preferably comprises a segmented air cell cushion **10**, such as a single chamber high profile air cushion (ROHO Group, Belleville, Ill.) classified by CMS as an adjustable, skin protection cushion which provides suitable redistribution of pressure and shear. The overall construction of individual cells **21** allows for site-specific additions of interface cooling elements **22**. Segmented air cell cushions **10**, such as the ROHO brand shown in FIG. 1, use a system of cells **21** interconnected by channels that allow air to flow at a controlled rate from cell to cell. As this occurs, the bony prominences are immersed and enveloped

in the cushion material, increasing the contact area and distributing the applied force on the buttocks or other supported body part. Thus, the cushioning surfaces **20** of the present disclosure may be used in wheelchair seating/support applications and other applications including, without limitation, beds, mattresses, mattress overlays, operating table pads, face masks, helmets and shoe insoles. A properly inflated segmented air cushion **10** will allow a seated person to sink to roughly 0.5" of clearance between the buttocks and the bottom of the cushioning surface **22**; the internal pressure of the cushioning surface **20** supports the applied load of a seated/supported person. Preferably, a heat exchange material pad **23** is disposed into such clearance space of select cells **21** and cooled by a TEC **28** and an air-cooled heat sink **30**, as shown in FIGS. **2**, **3**, **5**, **5A**, **6** and **7**.

In another preferred embodiment, heat sink **30** is water-cooled or liquid-cooled and also located external to cushioning surface **20** and allows for placement of a majority of the waste heat removal components to a position underneath or behind the seat of wheelchair **15** while leaving a slimmer cooling plate component of heat sink **30** immediately below cushioning surface **20**. Heat sink **30** in this water-cooled or liquid-cooled embodiment preferably comprises a ½ inch thick cold plate 3.5 inches wide and 12 inches long, which provides a surface area that will encompass all required TECs **28** corresponding with individually cooled cells **21A** in cushioning surface **20**. Preferably, copper tubing is embedded within the aluminum cold plate allowing liquid/water to be pumped through it to remove the waste heat from the TECs **28**. Flexible tubing preferably connects to the ends of this copper tubing allowing the water to be directed from the cold plate to a passive radiator system located behind/below the seat of wheelchair **15** to dissipate the heat.

As shown particularly in FIG. **5**, pads **23** of individual cooling elements **22** preferably are inserted through the base **24** of cushioning surface **20** into the individual air chambers **21**. The gel pad **23** preferably is positioned atop a TEC **28** and the chamber **21** resealed around the TEC **28** using neoprene epoxy to maintain the internal pressure of the cushioning surface **20** used to support the user or load. The hot side **28A** of the TEC **28** is fixed to or associated with heat sink **30** to draw the generated heat away from the TEC **28** and gel pad **23**. As the air cells **21** deform, the buttocks or other body part depending upon the application of the cushioning surface **20** would come in contact with the gel pad **23**, which is cooled by the TEC **28** situated, disposed in or otherwise associated with base **24** of cushioning surface **20**. Preferably, individual cells **21A** having cooling elements **22** associated therewith are arranged in arrays **19** throughout the cushioning surface **20** depending on the needs of the user, as shown in FIG. **4**. Different patterns/zones **19** beneath a user could be individually controlled and calibrated to cover small or large areas of targeted cooling.

A preferred cushioning surface **20** was fabricated according to the present disclosure as shown particularly in FIGS. **2-7** and **11-16** and comprises a single chamber, high profile ROHO cushion **10** (model: 1R99C) disposed upon support frame **32** whose height accommodated the heat sink **30** and cooling fan **31**. The heat sink **30** preferably was machined from aluminum to a 76.2×63.5×63.5 mm block (3)(2.5)(2.5 in.) and has a basic fin design (spaced 2 mm apart) to allow convection to dissipate the heat created by TECs **28**. Aluminum **6061** was used due to its thermal properties and ease of machining (specific heat A1 6061: 0.896 J/g·° C., thermal conductivity: 167 W/m-K). A Hengshan (Hengshan Group, FS70252M, Taiwan). CPU cooling fan **31** was oriented perpendicular to the fins with the design of increasing

convection to ambient air. Gel pad **23** was set into the base of cushioning surface **20** located where the left ischial tuberosity (IT) was expected to be immersed into the cushioning surface **20**. FIG. **6** shows several views of this preferred design with the dashed line **17** around buttocks of a seated person illustrates the alignment of the seated user on cushioning surface **20**.

Preferred gel or heat exchange pads **23** for use in the cushioning surface **20** of the present disclosure comprise glycerin hydrogels bound in urethane film and press fit into the base of a cell **21** of cushioning surface **20**. Each gel pad **23** of this design is designed to cool approximately 645.16 mm² (1 in²) while in contact with the buttocks or other deep immersed tissue.

The interface between the gel pad **23** and TEC **28** preferably is coated in a thin layer of thermal grease **27** (Thermal Joint Compound, Wakefield Thermal Solutions, Pelham N.H.) to increase heat conduction. The border **26** surrounding the bottom **24** of severed air chamber **21** preferably is sealed with airtight thermal epoxy (Royal Adhesives & Sealants, LLC, Belleville N.J.). This prevents any appreciable loss of air pressure from within cushioning surface **20**.

Preferred closed-loop TECs **28** (TE Technology, Traverse City, Mich.) are used to keep skin interface temperature at approximately 25° C. TEC **28** (TE-71-1.0-1.3) and heat sink preferably may be attached using a press fit and thermal grease. Two thermistors **29** (MP-2444) preferably were placed in the system to monitor interface temperature and send feedback to the temperature control board **35** (FIG. **8**) (TC-36-25-RS232). The feedback control thermistor **29** preferably may be imbedded within the gel pad **23**, and the interface thermistor **29** preferably may be placed between the seated participant and top of cushioning surface **20**. The control board **35** is a device that controls the voltage and the current that is delivered to the TEC **28** by receiving commands from an associated computer. The controller **35** preferably utilizes a proportional-integral-derivative (PID) control scheme to maintain the temperature of the TEC **28**. As shown in FIGS. **9-10**, the board **35** preferably may be controlled from a Labview program **37** (Version 8.6, National Instrument, Austin, Tex.) which transmitted all parameters of the controller program. The program **37** preferably is capable of recording temperature vs. time data in ASCII files and displayed the controller and interface temperatures in real time.

Optimal use of the PID controller **35** depended upon the location of the sensing thermistor **29** that would give feedback to the system for the closed loop control. As shown in FIG. **11**, preferred locations of the sensing thermistor **29** included within the supporting gel pad **23**, atop the supporting gel pad **23**, below the gel pad **23** directly in contact with TEC **28**, and outside the cooling element **22** on the skin of the seated individual. To evaluate the effect of location of thermistor **29** and set point on interface temperature delivery, an experiment was conducted using a preferred hydrogel gel pad **23**. The goal was to determine which preferred setups would approach 25±1° C. The highest temperature set point possible was preferred, since the TEC **28** requires proportionally more power and generates more heat as the target temperature decreases. The conditions tested were 20, 15, and 10° C. temperature set points. The locations of control thermistor **29** investigated included within the gel pad **23**, atop the gel pad **23**, and between the gel pad **23** and TEC **28**. Thermistor control at the skin was not evaluated as it was deemed impractical for standard everyday use of a functional cushioning surface **20**. The most successful trials were 15 or 10° C. set points with the control thermistor **29**

placed within the gel pad **23** or on top of gel pad **23**. Set point and location combinations with the lowest power requirements and generated heat are preferred. A set point of 15° C. combined with the control thermistor within the gel pad **23** effectively produced an interface temperature of 25±1° C. (max stdev=0.85° C. during steady state). The TEC **28** temperature also oscillated at 15±0.2° C., which demonstrated the control board **35** was operating within its appropriate bandwidth.

As shown in FIG. **12**, preferred heat exchange materials for gel pads **23** include (i) a glycerin hydrogel **23A** bound in urethane film, (ii) a polyurethane gel **23B** modified with ceramic microspheres and (iii) a polyurethane gel **23C** with resin microspheres. Each material was designed to maximize thermal conductivity while still providing adequate cushion support at the interface with the buttocks or other supported body part. According to another preferred embodiment of the present disclosure, the size of the gel pads **23** was increased slightly, as shown in FIG. **13**, in an attempt to minimize effects of weight shifts or leaning by the user causing gel pad **23** to lose contact with an associated TEC **28**. Preferably, by increasing the height and width of gel pad **23**, more continuous contact between gel pad **23** and TEC **28** would be maintained with a user seated on or supported by cushioning surface **20**. Moreover, the polyurethane membrane binding the gel pad **23** was removed according to this preferred embodiment to increase thermal transfer between the TEC **28**, gel pad **23**, and application site **19**. Preferably, the larger gel pads **23** fully occupy a cell **21** of cushioning surface **20** but provide enough clearance to allow air redistribution between neighboring cells **21**. As shown in FIG. **14**, in this preferred embodiment only material from the underside **24** of cushioning surface **20** was removed leaving a void (FIG. **14A**) which is then filled with a larger gel pad **23**, which is held in place by compressive forces and secured using Neo-rez neoprene epoxy (Wahoo International Inc., Oceanside Calif.) (FIG. **14B**). After curing, the control thermistor **29** preferably is punctured into the body of gel pad **23**, and a small amount of epoxy is used to secure it in place. Finally, this cooling element **22** is covered in thermal grease **27** (FIG. **14C**) to facilitate heat transfer to a TEC **28** unit aligned below it (see FIGS. **2-3**, **5**, **5A**, **6** and **11**).

FIGS. **15-16** illustrate a preferred embodiment of a wheelchair **15** having a seat comprising a cushioning surface **20** of the present disclosure. In this embodiment, support base **32** of cushioning surface **20** was modified to fit a 16"×17" Quickie (Breezy Ultra 4) wheelchair frame. A drop seat platform was machined to accommodate the aluminum heat sink **30** below a seated user. A cooling fan **31** from Delta Products (SFB0212HH-F00, Fremont Calif.) is preferably aligned perpendicular to the orientation of the fins to increase convective heat transfer. Fan **31** offered a wider cooling area with dual rotors and dimensions that matched those of the heat sink **30**. The fan **31** and heat sink **30** were aligned to where cell **21A** (containing cooling element **22** comprising heat exchange pad **23** and TEC **28**) would be located to align with an IT to be cooled in normal seating position.

It should be understood that while this disclosure has been described herein in terms of specific, preferred embodiments set forth in detail, such embodiments are presented by way of illustration of the general principles of the disclosure, and the disclosure is not necessarily limited thereto. Certain modifications and variations in any given material, process step or chemical formula will be readily apparent to those skilled in the art without departing from the true spirit and

scope of the present disclosure, and all such modifications and variations should be considered within the scope of the claims that follow.

What is claimed is:

1. A cushioning surface for cooling a body part or tissue immersed into the cushioning surface, comprising:
 - a segmented fluid cushion comprising a plurality of cells interconnected to allow fluid to flow from each cell to at least one of the other plurality of cells;
 - wherein each of the cells comprises first and second opposing sides and one or more sidewalls which collectively define a chamber in which part of the fluid is disposed;
 - wherein one or more of the plurality of cells contains heat exchange material disposed in a clearance space within the chamber in each such cell near the second side of the cell;
 - a cooling element associated with and for removing heat from the one or more cells containing the heat exchange material, wherein the heat exchange material in each of the one or more cells is disposed on or very near the cooling element; and
 - wherein the heat exchange material in each of the one or more cells is disposed between the first and second sides so that only a body part or tissue reaching a level of immersion into the cushioning surface from the first side to the second side and into or near the clearance space of the one or more cells containing heat exchange material is cooled by such cells and the cooling element.
2. The cushioning surface of claim 1 wherein the fluid is air.
3. The cushioning surface of claim 1 wherein the cooling element comprises a powered thermoelectric cooler.
4. A cushioning surface for cooling a body part or tissue immersed into the cushioning surface, comprising:
 - a segmented fluid cushion comprising a plurality of cells interconnected to allow fluid to flow from each cell to at least one of the other plurality of cells;
 - wherein each of the cells comprises first and second opposing sides and one or more sidewalls which collectively define a chamber in which part of the fluid is disposed;
 - wherein one or more of the plurality of cells contains a heat exchange material disposed in a clearance space within the chamber in each such cell near the second side of the cell;
 - a separate cooling element associated with each of the one or more cells containing the heat exchange material; wherein the heat exchange material in each of the one or more cells is disposed on or very near its separate cooling element; and
 - wherein the heat exchange material in each of the one or more cells is disposed between the first and second sides so that only a body part or tissue reaching a level of immersion into the cushioning surface from the first side to the second side and into or near the clearance space of the one or more cells containing heat exchange material is cooled by such cells and their respective cooling elements.
5. The cushioning surface of claim 4 wherein each cooling element comprises a powered thermoelectric cooler.
6. The cushioning surface of claim 4 wherein each of the one or more cells containing the heat exchange material and having the separate cooling element associated therewith corresponds to an area where immersion of a body part or tissue, from a body supported by the cushioning surface,

11

extends into or near the clearance space of the one or more cells containing heat exchange material.

7. The cushioning surface of claim 4 wherein each of the one or more cells containing the heat exchange material and having the separate cooling element associated therewith corresponds to an area where immersion of a body part or tissue, from a person seated on the cushioning surface, extends into or near the clearance space of the one or more cells containing heat exchange material.

8. A cushioning surface for cooling a body part or tissue immersed into the cushioning surface, comprising:

a segmented fluid cushion comprising a plurality of cells interconnected to allow fluid to flow from each cell to at least one other of the plurality of cells;

wherein each of the cells comprises first and second opposing sides and one or more sidewalls which collectively define a chamber in which part of the fluid is disposed;

wherein a plurality of the plurality of cells contains a heat exchange material disposed in a clearance space within the chamber space in each such cell near the second side of the cell;

a separate cooling element associated with each of the cells containing heat exchange material, wherein the heat exchange material in each of the cells is disposed on or very near its separate cooling element; and

wherein the heat exchange material in each of the plurality of the plurality of cells is disposed between the first and second sides so that only a body part or tissue reaching a level of immersion into the cushioning surface from the first side to the second side and into or near the clearance space of the one or more of the cells containing heat exchange material is cooled by such cells and their respective cooling elements.

9. The cushioning surface of claim 8 wherein each cell containing the heat exchange material and having the separate cooling element associated therewith corresponds to an area where immersion of a body part or tissue extends into

12

or near the clearance space of the one or more of the cells containing heat exchange material from a body supported by the cushioning surface.

10. The cushioning surface of claim 8 wherein each cell containing the heat exchange material and having the separate cooling element associated therewith corresponds to an area where immersion of a body part or tissue extends into or near the clearance space of the one or more of the cells containing heat exchange material from a person seated on the cushioning surface.

11. The cushioning surface of claim 8 wherein each of the separate cooling elements comprises a powered thermoelectric cooler.

12. A cushioning surface for cooling a body part or tissue immersed into the cushioning surface, comprising:

a segmented air cushion comprising a plurality of cells interconnected to allow air to flow from each cell to at least one other of the plurality of cells;

wherein each of the cells comprises first and second opposing sides and one or more sidewalls which collectively define a chamber in which part of the air is disposed;

wherein one of the plurality of cells contains a heat exchange material disposed in a clearance space within the chamber in the one cell near the second side of the cell;

a cooling element associated with the one cell containing the heat exchange material wherein the heat exchange material in the one cell is disposed on or very near the cooling element; and

wherein the heat exchange material in the one cell is disposed between the first and second sides so that only a body part or tissue reaching a level of immersion into the cushioning surface from the first side to the second side and into or near the clearance space of the one cell containing heat exchange material is cooled by the cushioning surface.

* * * * *